

Sub-SQL Sensitivity via Optical Rigidity in Advanced LIGO Interferometer with Optical Losses

F. Ya. Khalili, V. I. Lazebny, S. P. Vyatchanin

Physics Department, Moscow State University, Moscow 119992 Russia

(Dated: September 27, 2005)

The “optical springs” regime of the signal-recycled configuration of laser interferometric gravitational-wave detectors is analyzed taking in account optical losses in the interferometer arm cavities. This regime allows to obtain sensitivity better than the Standard Quantum Limits both for a free test mass and for an ordinary harmonic oscillator. The optical losses restrict the gain in sensitivity and achievable signal-to-noise ratio. Nevertheless, for parameters values planned for the Advanced LIGO gravitational-wave detector, this restriction is insignificant.

I. INTRODUCTION

Signal-recycled “optical-springs” topology of interferometric gravitational-wave detectors [1, 2] is now considered a likely candidate to design the second generation of these detectors, such as Advanced LIGO [3, 4]. This topology offers an elegant way to overcome the Standard Quantum Limit (SQL) for a free mass — a characteristic sensitivity level when the measurement noise of the meter is equal to its back-action noise [5–7].

This method is based on the use of optical pondermotive rigidity which exists in detuned electromagnetic cavities [8, 9]. It turns the test masses in a gravitational-wave detector into harmonic oscillators, thus providing a resonance gain in test masses displacement signal [10, 11]. In the signal recycling topology, the pondermotive rigidity can be created relatively easy by adjusting position of the signal recycling mirror. In this case, only the signal (anti-symmetric) optical mode eigenfrequency is changed. The arm cavities and the power (symmetric) mode remain resonance-tuned causing, therefore, no additional problems with the pumping power.

In large-scale optical systems having bandwidth equal to or smaller than the signal frequency Ω , the optical rigidity has a complicated frequency dependence [2, 12–14]. This feature allows to obtain not one but two mechanical resonances and consequently two minima in the noise. Alternatively, these minima can be placed close to each other or even superimpose, thus providing a single wider “well” in the noise spectral density.

The former regime was explored in detail in several articles [1, 2, 14–17]. The latter was examined rather briefly in papers [13, 14]. At the same time, it looks very promising for detection narrow-band gravitational-wave signals with known frequencies, in particular, those from the neutron stars. In this article this we present an in depth analysis of this regime.

In Sec.II we consider dynamic properties of the frequency-dependent pondermotive rigidity in no optical loss case, including, in particular, an instability inherent to the electromagnetic rigidity. This section is based, in part, on the results obtained in the articles [13–15]

In Sec.III we compare the optical rigidity-based scheme with other methods of circumvent the SQL for a free mass and show that it has a significant advantage, namely, it is much less vulnerable to optical losses.

In Sec.IV we calculate the sensitivity of the Ad-

vanced LIGO gravitational-wave detectors in the double-resonance optical springs regime.

To clarify this consideration we try to avoid bulky calculations in the main text. In Appendix A we give detailed analysis and calculations of sensitivity and signal-to-noise ratio for Advanced LIGO interferometer. In Appendices B and C we provide calculations for simplified model without optical losses.

II. FREQUENCY-DEPENDENT OPTICAL RIGIDITY. NO OPTICAL LOSSES

A. “Conventional” v.s. “double” resonances

In a single Fabry-Perot cavity, the pondermotive rigidity is equal to [13, 14]:

$$K(\Omega) = \frac{2\omega_p \mathcal{E}}{L^2} \frac{\delta}{\mathcal{D}(\Omega)}, \quad \mathcal{D}(\Omega) = (-i\Omega + \gamma)^2 + \delta^2, \quad (1)$$

where Ω is the observation (side-band) frequency, ω_p is the pumping frequency, $\delta = \omega_p - \omega_o$ is the detuning, ω_o is the cavity eigenfrequency, L is its length, \mathcal{E} is the optical energy stored in the cavity, and γ is the cavity half-bandwidth.

In articles [14, 15] the signal-recycled gravitational-wave detectors topology was considered in detail and its equivalence to a single cavity was shown. It was shown, in particular, that Eq. (1) is valid for this topology too, with obvious substitution of γ and δ by the anti-symmetric optical mode half-bandwidth γ_0 and detuning δ_0 [see Appendix A and Eqs. (A26), (A28)]. Energy \mathcal{E} in this case is equal to the total optical energy stored in both interferometer arms:

$$\mathcal{E} = \frac{4I_c L}{c}, \quad (2)$$

where I_c is the power circulating in each arm. For the sake of consistency with other parts of the paper, notations δ_0 and γ_0 will be used throughout this paper.

It should be noted that for the narrow-band regimes which we dwell on, γ_0 have to be small:

$$\gamma_0 \ll \delta_0 \sim \Omega. \quad (3)$$

Therefore, we neglect for a while term γ_0 , setting

$$K(\Omega) = \frac{K_0 \delta_0^2}{\delta_0^2 - \Omega^2}, \quad (4)$$

where K_0 is the rigidity value at zero frequency:

$$K_0 = \frac{2\omega_p \mathcal{E}}{L^2 \delta_0}. \quad (5)$$

A detailed analysis is provided in II B and IV.

Consider a harmonic oscillator having mass m and rigidity (1). We can write the equation of motion as follows:

$$m \frac{d^4 x(t)}{dt^4} + m \delta_0^2 \frac{d^2 x(t)}{dt^2} + \delta_0^2 K_0 x(t) = \frac{d^2 F(t)}{dt^2} + \delta_0^2 F(t), \quad (6)$$

where x is the oscillator coordinate and F is an external force acting on it.

In general the system has two resonances with frequencies

$$\Omega_{\pm} = \sqrt{\frac{\delta_0^2}{2} \pm \sqrt{\frac{\delta_0^4}{4} - \frac{\delta_0^2 K_0}{m}}}. \quad (7)$$

In articles [1, 2, 15] they are referred to as “mechanical” and “optical”, because in asymptotic case $K_0 \rightarrow 0$, the frequencies are equal to:

$$\Omega_+ = \delta_0, \quad \Omega_- = \sqrt{\frac{K_0}{m}}, \quad (8)$$

Therefore, the high-frequency resonance can be readily interpreted as a result of the optical power sloshing between the optical cavity and detuned pumping field, and the low-frequency one — as a conventional resonance of mechanical oscillator with K_0 rigidity.

The second-order pole [13, 14], or double resonance case takes place if these two frequencies are equal to each other:

$$\Omega_+ = \Omega_- = \Omega_0 = \frac{\delta_0}{\sqrt{2}}, \quad (9)$$

i.e. if

$$K_0 = \frac{m \delta_0^2}{4} \Leftrightarrow \mathcal{E} = \mathcal{E}_{\text{crit}}, \quad (10)$$

where

$$\mathcal{E}_{\text{crit}} = \frac{m L^2 \delta_0^3}{8 \omega_0} \quad (11)$$

is the critical energy. In this case, the equation of motion (6) has the following form:

$$m \left(\frac{d^2}{dt^2} + \Omega_0^2 \right)^2 x(t) = \frac{d^2 F(t)}{dt^2} + 2 \Omega_0^2 F(t). \quad (12)$$

It is useful to consider action of resonance force $F(t) = F_0 \cos \Omega_0 t$ on this system. Solving Eq. (12), we obtain:

$$x(t) = \frac{F_0}{8m} \left(-t^2 \cos \Omega_0 t + \frac{t \sin \Omega_0 t}{\Omega_0} \right). \quad (13)$$

The leading term in amplitude of $x(t)$ grows with time as t^2 . At the same time, for a conventional oscillator we have

$$x(t) = \frac{F_0 t \sin \Omega_0 t}{2m \Omega_0}, \quad (14)$$

and for a free mass,

$$x(t) = \frac{F_0 (1 - \cos \Omega_0 t)}{m \Omega_0^2}. \quad (15)$$

Therefore, response of the “double resonance” oscillator on the resonance force is $(\Omega_0 t/4)$ times stronger than that of a conventional harmonic oscillator, and $(\Omega_0 t/4)^2$ times stronger than that of a free mass one.

It was shown in [13, 14], that due to this feature, the “double resonance” oscillator has much smaller value of the Standard Quantum Limit for narrow-band signals, than both free mass and conventional harmonic oscillators. It is convenient to express this gain in terms of dimensionless parameter

$$\xi^2 = \frac{S_h(\Omega)}{h_{\text{SQL}}^2(\Omega)}, \quad (16)$$

where S_h is the single-sided spectral density of detector noise normalized as the equivalent fluctuational gravitation wave h ,

$$h_{\text{SQL}}^2(\Omega) = \frac{8\hbar}{m L^2 \Omega^2} \quad (17)$$

is the value of S_h corresponding to SQL. For conventional SQL-limited gravitation wave detectors (with free test masses), $\xi \geq 1$.

It is shown in Appendix B, that in case of a conventional first-order resonance, the equivalent noise curve has a “well” at resonance frequency Ω_0 , which provides the gain in sensitivity:

$$\xi_{\text{oscill}} = \sqrt{\frac{\Delta \Omega}{\Omega_0}}, \quad (18)$$

where $\Delta \Omega$ is the bandwidth where this gain is provided. In particular, this gain can be obtained by using either the “mechanical” or “optical” resonance of optical rigidity).

In the case of “double resonance” oscillator, this gain can be substantially more significant:

$$\xi_{\text{dbl}} = \frac{\Delta \Omega}{\Omega_0} = \xi_{\text{oscill}} \sqrt{\frac{\Delta \Omega}{\Omega_0}}. \quad (19)$$

Even better result can be obtained if optical energy is slightly smaller than the critical value (11):

$$K_0 = \frac{m \delta_0^2}{4} (1 - \eta^2) \Leftrightarrow \mathcal{E} = \mathcal{E}_{\text{crit}} (1 - \eta^2), \quad \eta \ll 1. \quad (20)$$

In this case, function $\xi(\Omega)$ has two minima, which correspond to two resonance frequencies

$$\Omega_{\pm} = \Omega_0 \sqrt{1 \pm \eta} \approx \Omega_0 \left(1 \pm \frac{\eta}{2} \right), \quad (21)$$

and a local maximum at frequency Ω_0 . If parameter η is equal to the optimal value

$$\eta_c = \xi(\Omega_0), \quad (22)$$

then the bandwidth is $\sqrt{2}$ times wider than in pure double resonance case for the same value of ξ :

$$\xi_{\text{enh dbl}} = \frac{\xi_{\text{dbl}}}{\sqrt{2}} = \frac{\Delta\Omega}{\sqrt{2}\Omega_0}. \quad (23)$$

Above considerations give an important result concerning the signal-to-noise ratio values for different regimes [18].

The signal-to-noise ratio is equal to:

$$\text{SNR} = \frac{2}{\pi} \int_0^\infty \frac{|h(\Omega)|^2}{S_h(\Omega)} d\Omega, \quad (24)$$

where $h(\Omega)$ is the gravitation wave signal spectrum. It is shown in Appendix C, that for a conventional resonance-tuned interferometer (without optical springs),

$$\text{SNR}_{\text{no springs}} = \mathcal{N} \times \frac{|h(\Omega_0)|^2 \Omega_0}{h_{\text{SQL}}^2(\Omega_0)}, \quad (25)$$

where factor \mathcal{N} for wide band signal (with bandwidth $\Delta\Omega_{\text{signal}} \geq \Omega_0$) is about unity: for short pulse $\mathcal{N} \approx 2.0$ and for step-like signal $\mathcal{N} \approx 0.7$. For narrow-band signals with $\Delta\Omega_{\text{signal}} \ll \Omega_0$ we have $\mathcal{N} \sim \Delta\Omega_{\text{signal}}/\Omega_0$.

In the narrow-band cases described above the signal-to-noise ratio can be estimated as follows:

$$\text{SNR} \sim \frac{|h(\Omega_0)|^2 \Delta\Omega}{S_h(\Omega_0)} = \frac{\Delta\Omega}{\xi^2} \frac{|h(\Omega_0)|^2}{h_{\text{SQL}}^2(\Omega_0)}. \quad (26)$$

(we omit here a numeric factor of the order of unity). In case of a conventional harmonic oscillator, it can be shown using Eqs. (18,26), that:

$$\text{SNR}_{\text{oscill}} \approx \frac{2|h(\Omega_0)|^2 \Omega_0}{h_{\text{SQL}}^2(\Omega_0)} \quad (27)$$

(numeric factors in this formula and in Eq. (28) below are obtained through rigorous integration in Eq. (24), see Appendix C). This value *does not depend* on $\Delta\Omega$. Thus conventional harmonic oscillator provide arbitrary (in the case of zero losses) high sensitivity at resonance frequency, and also gain in signal-to-noise ratio equal to $\sim \Omega_0/\Delta\Omega_{\text{signal}}$ for narrow-band signals as compared with conventional interferometer. At the same time, the value (27) is fixed and can not be increased by improving the meter parameters, and there is no gain in signal-to-noise ratio for wide-band signals.

On the other hand, in case of double-resonance oscillator, it stems from Eqs. (19, 26), that:

$$\text{SNR}_{\text{dbl}} \approx \frac{\sqrt{2}\Omega_0}{\Delta\Omega} \times \frac{|h(\Omega_0)|^2 \Omega_0}{h_{\text{SQL}}^2(\Omega_0)} \approx \frac{\Omega_0}{\sqrt{2}\Delta\Omega} \times \text{SNR}_{\text{oscill}}. \quad (28)$$

Therefore, the double resonance oscillator allows to increase both the resonance frequency sensitivity and the signal-to-noise ratio by decreasing the bandwidth $\Delta\Omega$.

The signal-to-noise ratio for Advanced LIGO interferometer with optical rigidity and influence of optical losses is considered in Sec. IV C.

It is well known [8, 9] that *positive* pondermotive rigidity is accompanied by *negative* dumping, *i.e.* a pondermotive rigidity-based oscillator is always unstable. In case of frequency-dependent rigidity, this instability was calculated in article [12] (see also [1, 2]).

If the eigenfrequencies are separated well apart from each other, $\Omega_+ - \Omega_- \gg \gamma_0$, then the characteristic instability time equals to

$$\tau_{\text{instab}} \approx \left(\frac{\gamma_0 \Omega_0^2}{\Omega_+^2 - \Omega_-^2} \right)^{-1} \sim \gamma_0^{-1} \sim 0.1 \div 1 \text{ s}. \quad (29)$$

The instability becomes more strong, if $\Omega_+ - \Omega_- \rightarrow 0$. In double resonance case ($\Omega_+ = \Omega_-$), the instability time is equal to

$$\tau_{\text{instab}} \approx \frac{2}{\sqrt{\gamma_0 \Omega_0}}. \quad (30)$$

However, inequality $\Omega_0 \tau_{\text{instab}} \gg 1$ holds in this case too.

It has to be noted that, in principle, any instability can be dumped without affecting signal-to-noise ratio, if the feedback system sensor sensitivity is only limited by quantum noises [2].

III. COMPARISON WITH OTHER METHODS TO OVERCOME SQL AND INFLUENCE OF OPTICAL LOSSES

A. “Real” vs. “virtual” rigidities

From the Quantum Measurements Theory point of view, a laser interferometric gravitational-wave detector can be considered as a meter which continuously monitors position $\hat{x}(t)$ of a test mass m [2, 6, 7]. Output signal of this meter is equal to:

$$\tilde{x}(t) = \hat{x}(t) + \hat{x}_{\text{meter}}(t), \quad (31)$$

where $\hat{x}_{\text{meter}}(t)$ is the measurement noise and $\hat{x}(t)$ is the “real” position of the test mass. It includes its responses on the signal force

$$F_{\text{signal}}(t) = \frac{mL\ddot{h}(t)}{2} \quad (32)$$

and on the meter back-action force $\hat{F}_{\text{meter}}(t)$:

$$\hat{x}(t) = \mathbf{Z}^{-1}[F_{\text{signal}}(t) + \hat{F}_{\text{meter}}(t)] \quad (33)$$

(the terms containing the initial conditions can be omitted, see article [7]). Here \mathbf{Z} is a differential operator describing evolution of the test object. For a free test mass (*i.e.* for the initial LIGO topology),

$$\mathbf{Z} = m \frac{d^2}{dt^2}, \quad (34)$$

If rigidity K (including the frequency-dependent pondermotive one) is associated with the test mass, then

$$\mathbf{Z} = m \frac{d^2}{dt^2} + K \quad (35)$$

Therefore, the signal force estimate is equal to

$$\tilde{F}(t) \equiv \mathbf{Z}\tilde{x}(t) = F_{\text{signal}}(t) + \hat{F}_{\text{sum noise}}(t), \quad (36)$$

where

$$\hat{F}_{\text{sum noise}}(t) = \hat{F}_{\text{meter}}(t) + \mathbf{Z}\hat{x}_{\text{meter}}(t). \quad (37)$$

is the meter total noise.

The back-action noise $\hat{F}_{\text{meter}}(t)$ is proportional to the amplitude quadrature component of the output light. The measurement noise $\hat{x}_{\text{meter}}(t)$, in the simplest case of SQL-limited detector, is proportional to the phase quadrature component. In this case the spectral densities of these noises satisfy the following uncertainty relation (see e.g. [6]):

$$S_x S_F \geq \hbar^2. \quad (38)$$

In more sophisticated schemes which allow to overcome SQL, the noises $F_{\text{meter}}(t)$ and $\hat{x}_{\text{meter}}(t)$ correlate with each other. In this case, the back-action noise can be presented as follows:

$$F_{\text{meter}}(t) = F_{\text{meter}}^{(0)}(t) + \mathcal{K}\hat{x}_{\text{meter}}(t), \quad (39)$$

where $F_{\text{meter}}^{(0)}(t)$ is the back-action noise component non-correlated with the measurement noise and coefficient \mathcal{K} can be referred to as “virtual” rigidity.

Note that it is precisely the idea of quantum variational measurement [19–23]. In conventional optical position meters, including the LIGO interferometer, one measures the phase quadrature component in output wave. This component contains both the measurement noise (x_{meter}) produced by phase fluctuations in input light wave and the back action noise (F_{meter}) caused by amplitude fluctuations (optimization of the sum of these two uncorrelated noises produces SQL). However, using homodyne detector one can measure tuned mix of the phase and amplitude quadratures of output waves and this mix can be selected in such a way that the back action noise *can be compensated* by the noise of the amplitude quadrature. It can be considered as introduction of *correlation* between the back action and the measurement noises as presented in Eq. (39). We see that the “virtual” rigidity only relates to the measurement procedure (homodyne angle).

Substituting Eq (39) into Eq. (36), we obtain, that

$$\hat{F}_{\text{sum noise}}(t) = \hat{F}_{\text{meter}}^{(0)}(t) + \mathbf{Z}_{\text{eff}}\hat{x}_{\text{meter}}(t), \quad (40)$$

where

$$\mathbf{Z}_{\text{eff}} = \mathbf{Z} + \mathcal{K} = m \frac{d^2}{dt^2} + K_{\text{eff}}, \quad (41)$$

and

$$K_{\text{eff}} = K + \mathcal{K}. \quad (42)$$

is the *effective rigidity*.

Thus, *in the lossless case, the total meter noise (40) only contains the sum of real rigidity K and virtual one \mathcal{K} , and replacement of any one of them by another one does not change the total noise spectral density and the signal-to-noise ratio [24].*

Spectral densities of the noises $\hat{x}_{\text{meter}}(t)$ and $\hat{F}_{\text{fluct}}^{(0)}(t)$ also satisfy the uncertainty relation

$$S_x S_F^{(0)} \geq \hbar^2, \quad (43)$$

which does not permit simultaneously making both noise terms in Eq. (40) arbitrary small. However, factor \mathbf{Z}_{eff} can be made equal to zero by setting

$$K_{\text{eff}} = m\Omega^2. \quad (44)$$

In this case, only noise $\hat{F}_{\text{meter}}^{(0)}(t)$ remains in Eq. (40). In principle this noise can alone be made arbitrary small, thus providing arbitrary high sensitivity.

Both “real” and “virtual” (created by the noise correlation) can be used for this purposes. Applying the idea of variational measurement a simple frequency-independent cross-correlation (and thus frequency-independent virtual rigidity \mathcal{K}) can be created relatively easily by using a homodyne detector. In this case, Eq. (44) is fulfilled at some given frequency, creating resonance gain in sensitivity similar to one provided by a conventional harmonic oscillator.

A frequency-dependent cross-correlation and thus a frequency-dependent virtual rigidity \mathcal{K} can be induced through modification of the input and/or output optics of the gravitation-wave detectors using additional large-scale filter cavities [23]. In this case, condition (44) can be fulfilled and thus the sensitivity better than SQL is obtained in any given frequency range.

Consider now the real pondermotive rigidity. It is evident that it can not be tuned in such a flexible way as the virtual one. In the double-resonance case, graphics of $K(\Omega)$ and $m\Omega^2$ touch each other only at frequency Ω_0 . However, around this point,

$$(K_{\text{eff}}(\Omega) - m\Omega^2) \sim (\Omega - \Omega_0)^2, \quad (45)$$

instead of $\Omega - \Omega_0$ for the case of a conventional frequency-independent rigidity. As it was shown in Sec. II, slightly better results can be obtained by using sub-critical pumping $\mathcal{E} < \mathcal{E}_{\text{crit}}$, which provide two closely placed first-order resonances, see Fig. 1(b).

B. Influence of optical losses

It is possible to conclude from above considerations that the virtual rigidity provides a more promising solution than the real pondermotive one. However, as we show in this subsection, the pondermotive rigidity has one important advantage: it is much less vulnerable to losses in optical elements. Our consideration will be based on the following statement, which follows from Eqs. (A39): *a lossy optical position meter is equivalent to the similar lossless one with gray filter attached to its signal port.* This filter transmittance has to be equal to:

$$T_{\text{equiv}}^2 = \frac{\gamma_0^{\text{load}}}{\gamma_0}, \quad (46)$$

where

$$\gamma_0 = \gamma_0^{\text{load}} + \gamma_0^{\text{loss}}, \quad (47)$$

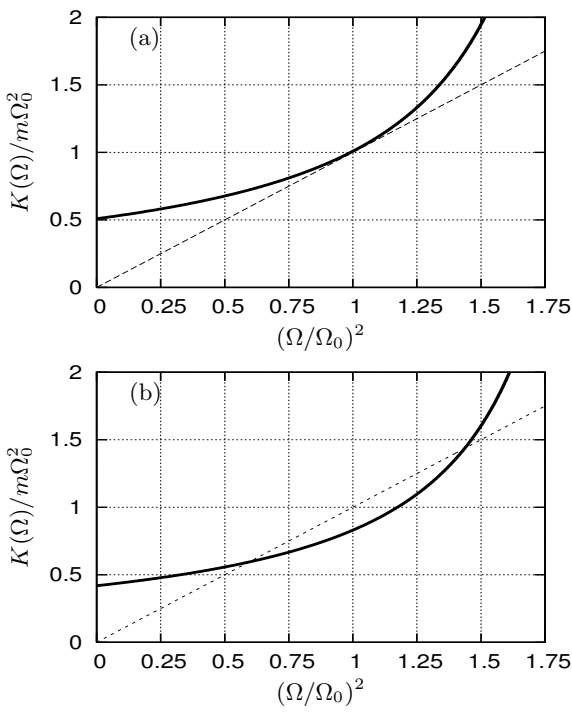

FIG. 1: Plots of the frequency-dependent rigidity $K(\Omega)$ as a function of Ω^2 (solid line); dashed line corresponds to $m\Omega^2$; (a) — critical pumping (the double resonance regime); (b) — sub critical pumping.

γ_0^{load} is the term describing signal mode half-bandwidth γ_0 describing coupling with photodetector and γ_0^{loss} is the term describing optical losses.

Term “similar” means, that (i) both meters have same dynamic parameters, *i.e.* bandwidths and eigenfrequencies of the cavities, etc. In particular, half-bandwidth of the lossless meter has to be equal to γ_0 and (ii) optical energies stored in the lossless meter and the lossy one have to be equal to each other.

Therefore, the lossy meter output signal can be presented in the following form (compare with Eq. (31)):

$$\hat{x}_{\text{lossy}}(t) = \hat{x}(t) + \hat{x}_{\text{meter}}(t) + |\mathcal{A}_0| \hat{x}_{\text{loss}}(t), \quad (48)$$

where

$$|\mathcal{A}_0| = \frac{\sqrt{1 - T_{\text{equiv}}^2}}{T_{\text{equiv}}} = \sqrt{\frac{\gamma_0^{\text{loss}}}{\gamma_0^{\text{load}}}} \quad (49)$$

is the effective loss factor and $\hat{x}_{\text{loss}}(t)$ is the additional noise produced by the optical losses uncorrelated with x_{meter} . Spectral density of this noise is also equal to S_x , because both $\hat{x}_{\text{loss}}(t)$ and $\hat{x}_{\text{loss}}(t)$ are in essence zero-point fluctuations normalized by the transfer function of measurement system. The key point is that while the back-action noise $\hat{F}_{\text{meter}}(t)$ can correlate with the measurement noise $\hat{x}_{\text{meter}}(t)$, it *can not correlate* with additional noise $\hat{x}_{\text{loss}}(t)$:

$$\hat{F}_{\text{sum noise}}(t) = \hat{F}_{\text{meter}}^{(0)}(t) + \mathbf{Z}_{\text{eff}} \hat{x}_{\text{meter}}(t) + |\mathcal{A}_0| \mathbf{Z} \hat{x}_{\text{loss}}(t) \quad (50)$$

[compare with Eq. (40)].

It follows from this equation that in the lossy meter case there is no symmetry of the real and virtual rigidities: the term proportional to the meter noise $\hat{x}_{\text{meter}}(t)$ still depends on the effective rigidity, but the new losses term only depends on the real rigidity.

Compare now two particular cases of “pure real” and “pure virtual” rigidities.

In the first case, $\mathbf{Z}_{\text{eff}} = \mathbf{Z}$, and

$$\hat{F}_{\text{sum noise}}(t) = \hat{F}_{\text{meter}}^{(0)}(t) + \mathbf{Z} [\hat{x}_{\text{meter}}(t) + |\mathcal{A}_0| \hat{x}_{\text{loss}}(t)]. \quad (51)$$

Therefore, both terms proportional to $\hat{x}_{\text{meter}}(t)$ and $\hat{x}_{\text{loss}}(t)$ can be canceled by setting $\mathbf{Z} = 0$, thus providing arbitrary high sensitivity at least for one given frequency.

In the second case,

$$\hat{F}_{\text{sum noise}}(t) = \hat{F}_{\text{meter}}^{(0)}(t) + \mathbf{Z}_{\text{eff}} \hat{x}_{\text{meter}}(t) - m\Omega^2 |\mathcal{A}_0| \hat{x}_{\text{loss}}(t). \quad (52)$$

Suppose that \mathbf{Z}_{eff} is canceled using some QND procedure. In this case, the sum noise will still consist of two non-correlated parts proportional to $\hat{F}_{\text{meter}}^{(0)}(t)$ and $\hat{x}_{\text{loss}}(t)$, and its spectral density will be equal to:

$$S_{\text{sum}}(\Omega) = S_F^{(0)} + m^2 \Omega^4 |\mathcal{A}_0|^2 S_x. \quad (53)$$

Taking into account uncertainty relation (43), it is easy to see that

$$S_{\text{sum}}(\Omega) \geq 2 |\mathcal{A}_0| \hbar m \Omega^2, \quad (54)$$

or

$$\xi \equiv \sqrt{\frac{S_{\text{sum}}(\Omega)}{S_{\text{SQL}}(\Omega)}} \geq \sqrt{|\mathcal{A}_0|} = \left(\frac{\gamma_0^{\text{loss}}}{\gamma_0^{\text{load}}} \right)^{1/4}, \quad (55)$$

where

$$S_{\text{SQL}}(\Omega) = \frac{m^2 L^2 \Omega^4}{4} h_{\text{SQL}}^2(\Omega) = 2 \hbar m \Omega^2 \quad (56)$$

[see Eqs. (17,32)].

The restriction (55) shows that the use of “pure virtual” rigidity (variational measurement) is very sensitive to losses — for parameters from Table I we have $(\gamma_0^{\text{loss}}/\gamma_0^{\text{load}})^{1/4} \simeq 0.7$ (!).

For conventional (resonance-tuned) Advanced LIGO topology, $\gamma_0 \simeq \Omega \simeq 2\pi \times 100\text{s}^{-1} \gg \gamma_0^{\text{loss}}$ and “virtual” rigidity can be introduced by means of the variational measurement. In this case the optical losses restrict the sensitivity by the following value:

$$\xi \simeq \left(\frac{\gamma_0^{\text{loss}}}{\Omega} \right)^{1/4} \simeq 0.2 \quad (57)$$

(for the value of γ_0^{loss} , see Table I).

In general both real and virtual rigidities exist in the signal-recycled configuration of the interferometric gravitation-wave detectors as well as for that of a single detuned cavity. However, in the narrow-band regimes (3), the real rigidity dominates: it is approximately δ_0/γ_0 times stronger than the virtual one (compare Eqs. (A34) and (A50), or (A53a) and (A53b), which differ by terms of the order of magnitude $\lesssim \gamma_0/\delta_0$ only). Due to this reason, this regime is free from limitation (55).

It is also interesting to note that while both K and \mathcal{K} contain, in general, imaginary parts, in effective rigidity K_{eff} these imaginary parts exactly compensate each other.

TABLE I: Parameters planned to use in Advanced LIGO [3]. In estimates of $|\mathcal{A}_0|^2$ and γ_0 using formulas (47,49,A26) we assume that $|1 + R_s e^{2i\phi}|^2 \simeq 2$

Transmissivity of SR mirror	$T_s^2 = 0.05$
Transmissivity of input mirrors in arms	$T^2 = 0.005$
Loss coefficient of each mirror in arms	$\mathcal{A}_1^2 = \mathcal{A}_2^2 = 1.5 \times 10^{-5}$
Length of interferometer arm	$L = 4$ km
Effective loss factor	$ \mathcal{A}_0 ^2 = 0.24$
Relaxation rate of difference mode	$\gamma_0 = 2.9$ s ⁻¹
“Intrinsic” relaxation rate	$\gamma_0^{\text{loss}} = 0.56$ s ⁻¹
Mean frequency of gravitational wave range	$\Omega_0 = 2\pi \times 100$ s ⁻¹

IV. ADVANCED LIGO SENSITIVITY IN DOUBLE-RESONANCE REGIME

A. The sum noise spectral density

Sensitivity of the signal-recycled Advanced LIGO topology in the narrow-band approximation (close to the double resonance) is calculated in Appendix A. It is shown, that in this case [see Eq. (A57)]

$$\xi^2(\Omega) \approx \xi_0^2 + \frac{|\mathcal{A}_\alpha|^2}{4\gamma_0^{\text{loss}}\Omega_0^3} (4\nu^2 - \eta_\alpha^2\Omega_0^2)^2 \quad (58)$$

where $\nu = \Omega - \Omega_0$,

$$\xi_0^2 = \frac{\gamma_0^{\text{loss}}}{\Omega_0|\mathcal{A}_\alpha|^2} C, \quad C = 1 + \frac{3}{\sqrt{2}}|\mathcal{A}_\alpha|^2 + |\mathcal{A}_\alpha|^4, \quad (59)$$

and η_α , $|\mathcal{A}_\alpha|$ are basically parameters η , $|\mathcal{A}_0|$ corrected to take into account virtual rigidity (*i.e.* homodyne angle α), see Eqs. (A55).

It follows from Eq. (58) that the single minimum dependence of sensitivity $\xi(\Omega)$ takes place if $\eta_\alpha = 0$ with bandwidth $\Delta\Omega$ equal to

$$\Delta\Omega = \sqrt{2\gamma_0^{\text{loss}}\Omega_0 \frac{\sqrt{C}}{|\mathcal{A}_\alpha|^2}}. \quad (60)$$

On Figs. 2, 3 we present the sensitivity plots for various sets of parameters which allows to realize single minimum dependence of ξ on different frequencies Ω_0 and with different depths. In order to emphasize the role of optical losses, a rather large value of the effective loss factor $|\mathcal{A}_0| = 1$ is used. However, even in this case the sensitivity degradation due to the losses is small. Possibility of scaling the frequency Ω_0 is also demonstrated in this plots.

For $\eta > 0$ we have two minima dependence of sensitivity ξ at two different frequencies $\Omega_\pm \simeq \Omega_0\sqrt{1 \pm \eta}$. With increase of η the distance between minima also increases. Comparing values $\xi(\Omega_\pm)$ with $\xi(\Omega_0)$ we can introduce a “characteristic” value $\eta_{\alpha c}$ when $\sqrt{2}\xi(\Omega_\pm) = \xi(\Omega_0)$:

$$\eta_{\alpha c} = \frac{\xi_0}{C^{1/4}}. \quad (61)$$

In this case

$$\xi_0^2 = \frac{2\gamma_0^{\text{loss}}}{\Omega_0|\mathcal{A}_\alpha|^2} C = \frac{\sqrt{C}}{2} \frac{\Delta\Omega^2}{\Omega_0^2}. \quad (62)$$

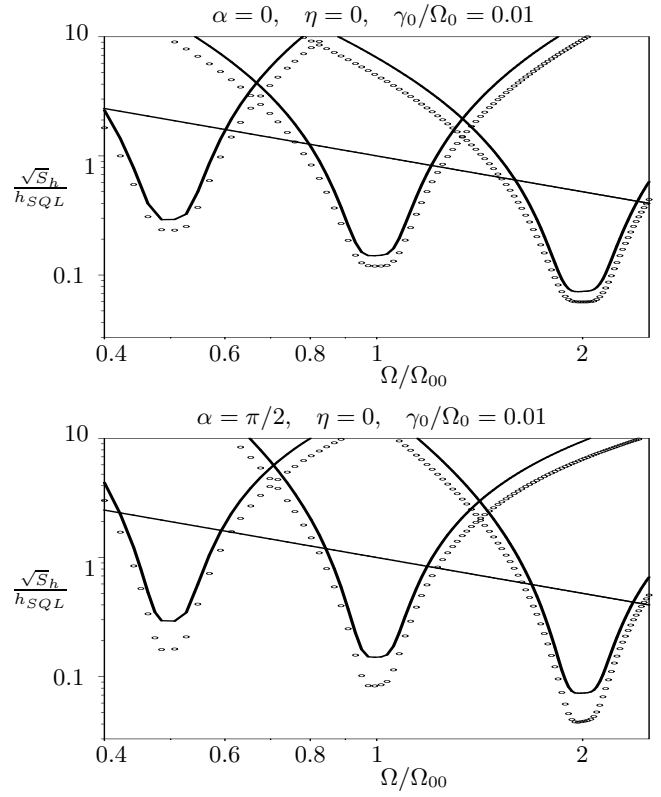

FIG. 2: Top plot: function $\sqrt{S_h(\Omega)}/h_{SQL}(\Omega_{00})$ plotted for parameters $\alpha = 0$, $\gamma_0/\Omega_0 = .01$, $|\mathcal{A}_0| = 1$ and $\eta_\alpha = 0$. The left solid curve — $\Omega_0 = 0.5 \times \Omega_{00}$, the middle solid curve — $\Omega_0 = \Omega_{00}$ and the right solid curve — $\Omega_0 = 2 \times \Omega_{00}$. The dotted curves — sensitivity for no loss case with $\gamma_0^{\text{no losses}} = \gamma_0$. Straight line depicts SQL sensitivity. Bottom plot: the same as on top plot with homodyne angle $\alpha = \pi/2$. Ω_{00} is some arbitrary frequency, for example, $\Omega_{00} = 2\pi \times 100$ s⁻¹.

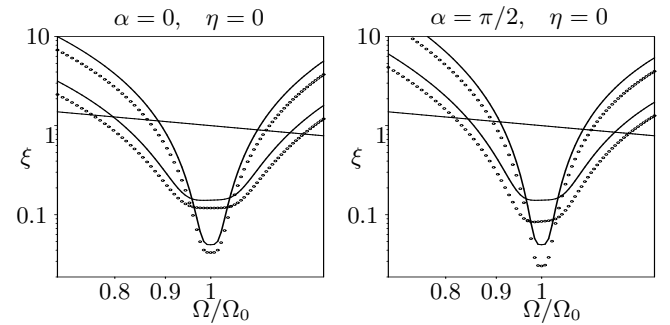

FIG. 3: Left plot: sensitivity curves $\xi(\Omega)$ plotted for parameters $\alpha = 0$, $\Omega_0 = \Omega_0$, $|\mathcal{A}_0| = 1$ and $\eta = 0$. The wider solid curve corresponds to $\gamma_0/\Omega_0 = .01$, the narrower solid curve — $\gamma_0/\Omega_0 = .001$. The dotted curves — sensitivity for no loss case with $\gamma_0^{\text{no losses}} = \gamma_0$. Straight line depicts SQL sensitivity. Right plot: the same as on the left plot for homodyne angle $\alpha = \pi/2$.

[compare with Eq. (23)]. The sensitivity plots for this case (again for enlarged loss factor $|\mathcal{A}_0| = 1$) are given in Fig. 4.

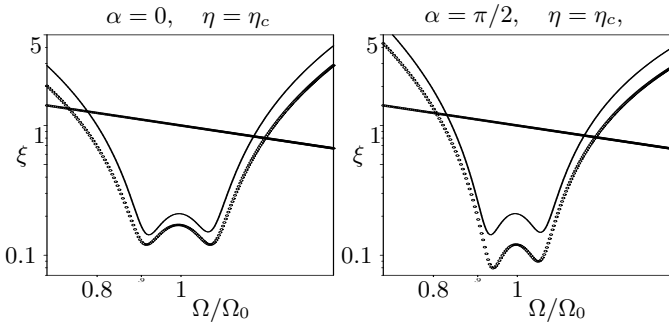

FIG. 4: Left plot: sensitivity curves ξ plotted for parameters $\alpha = 0$, $\gamma_0/\Omega_0 = .01$, $|\mathcal{A}_\alpha| = 1$ and $\eta = \eta_c$. The dotted curves — sensitivity for no loss case with $\gamma_0^{\text{no losses}} = \gamma_{0+}$. Straight line depicts SQL sensitivity. Right plot: the same as on the left plot with homodyne angle $\alpha = \pi/2$.

B. Minimum of the spectral density

Suppose that almost monochromatic signal has to be detected and we are interested in the minimum of normalized spectral density ξ at some fixed frequency. First of all we have to remind that γ_0^{loss} is fixed (it depends on mirror's absorption only) whereas the effective loss factor $|\mathcal{A}_0|^2$ (as well as $|\mathcal{A}_\alpha|^2$) can be modified by variation of mirrors transmissivities.

It follows from Eq. (58) that $\xi(\Omega)$ reaches its minimum at $\nu = \pm\eta_\alpha\Omega_0/2$ and $|\mathcal{A}_\alpha| = 1$, and this minimum is equal to

$$\xi_{\min} = \sqrt{\frac{\gamma_0^{\text{loss}}}{\Omega_0} \left(2 + \frac{3}{\sqrt{2}}\right)} \simeq 0.06 \quad (63)$$

[compare with Eq. (57)]. Here for the estimate we used parameters from Table I.

Unfortunately, this value can not be obtained for planned Advanced LIGO parameters. Indeed, it follows from Eqs. (A26), (A28), that

$$\delta_0 < \frac{2\gamma_0^{\text{load}}}{T_s^2}, \quad (64)$$

(The physical sense of $\gamma_0^{\text{load}}/T_s^2$ is quite clear — it is relaxation rate of a single FP cavity in one arm.) In the double resonance regime we need to have $\delta_0 \approx \sqrt{2}\Omega_0 \approx 10^3 \text{ s}^{-1}$. However for Advanced LIGO parameters (Table I)

$$\frac{2\gamma_0^{\text{load}}}{T_s^2} \simeq 100 \text{ s}^{-1} \quad (65)$$

It is less by one order of magnitude than required. The problem can be solved through modifying Advanced LIGO parameters, namely, by decreasing the signal recycling mirror transmittance T_s^2 by approximately one order of magnitude and corresponding increase in the arm cavities input mirrors transmittance by the same value.

C. Signal-to-noise ratio

As was mentioned above, the double-resonance regime allows to obtain signal-to-noise ratio better than SQL

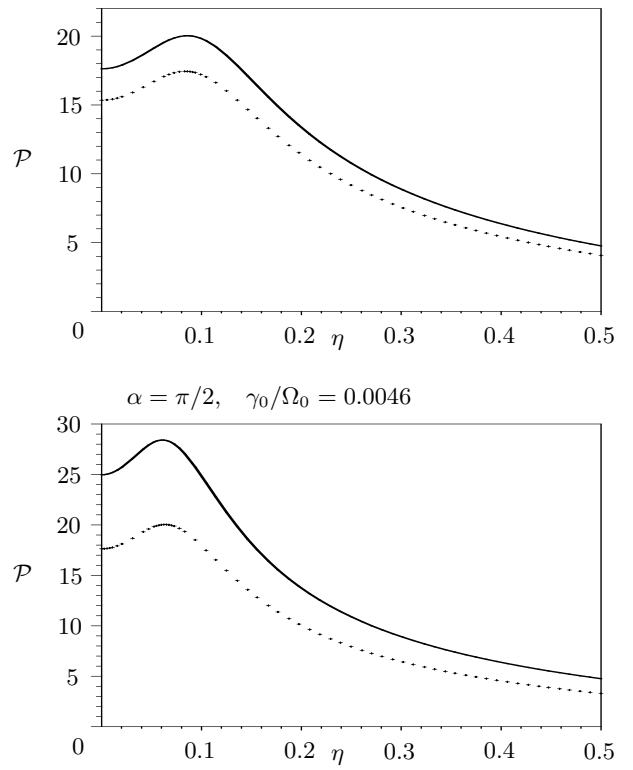

FIG. 5: Numerically calculated plots of signal-to-noise ratio gain $\mathcal{P}(\eta)$ for different homodyne angles: $\alpha = 0$ (top) and for $\alpha = \pi/2$ (bottom). On each plot the upper solid curve corresponds to no loss case, the lower dotted curve — to planned in Advanced LIGO losses with factor $|\mathcal{A}_0|^2 = 0.24$. All plots are calculated for fixed ratio $\gamma_0/\Omega_0 = 0.0046$, planned in Advanced LIGO.

even for wide-band signals. It was shown in [14] that for no loss case the gain in signal-to-noise ratio, in principle, can be arbitrary high. Here we show that optical losses restrict this gain. The details of calculations are presented in Appendix A 9.

As an example of wide band signal we consider the perturbation of metric having the shape of a step function in time domain and the Fourier transform equal to

$$h(\Omega) = \text{const}/\Omega. \quad (66)$$

It is worth to underline that the result practically does not depend on the shape of wide band signal spectrum (as alternative example one could consider a short pulse (delta-function) — its Fourier transform is a constant).

To demonstrate the gain we also calculate the signal-to-noise ratio SNR_{conv} for conventional LIGO interferometer [23] without signal recycling mirror with registration of phase quadrature and take the quotient \mathcal{P} of SNR by SNR_{conv} in order to characterize the gain in signal-to-noise ratio (the value SNR_{conv} we calculated numerically):

$$\mathcal{P} = \frac{\text{SNR}}{\text{SNR}_{\text{conv}}}, \quad \text{SNR}_{\text{conv}} \simeq 0.7 \times \frac{h(\Omega_0)^2 \Omega_0}{h_{\text{SQL}}^2(\Omega_0)} \quad (67)$$

Using the accurate formulas (A44) we numerically calculated plots (see Fig. 5) for gain \mathcal{P} as function of η at fixed ratio $\gamma_0/\Omega_0 = 0.0046$ and loss factor factor

$|\mathcal{A}_0|^2 = 0.24$ corresponding to Advanced LIGO parameters (see Table I). We see that the degradation due to losses is not large as compared with no loss case.

The gain \mathcal{P} decreases with increase in η bigger than optimal — i.e. when double-resonance ($\eta = 0$) transforms to two well separated first-order resonances ($\eta \gg \eta_c$).

We see from plots in Fig. 5 that there is an optimal value of parameter η when gain has maximum. Analysis presented in Appendix A 9 shows that gain \mathcal{P} reaches its maximum for optimal values of η_α and $|\mathcal{A}|_\alpha$ and it is equal to

$$\mathcal{P}_{\max} \simeq 0.6 \times \sqrt{\frac{\Omega_0}{\gamma_0^{\text{loss}}}} \simeq 20 \quad (68)$$

where estimates given for parameters listed in Table I.

Note that this gain may be achieved at Advanced LIGO parameters — in bottom plot on Fig. 5 the maximum of dotted curve is quite close to \mathcal{P}_{\max} .

It is worth noting that in the “pure” double-resonance regime ($\eta_\alpha = 0$) the gain in the signal-to-noise ratio only slightly differs from the maximum gain:

$$\frac{\mathcal{P}_{\max}}{\mathcal{P}(\eta_\alpha = 0, |\mathcal{A}|_\alpha^{\text{opt}})} = \frac{3^{3/4}}{2} \simeq 1.14 \quad (69)$$

Using the signal-to-noise ratio for a conventional oscillator (27), one can calculate the gain

$$\mathcal{P}_{\text{osc}} = \frac{\text{SNR}_{\text{oscill}}}{\text{SNR}_{\text{conv}}} \simeq 2.8 \quad (70)$$

Comparing (68) and (70) we see that “double resonance” regime provides gain in signal-to-noise ratio about 7 times larger than conventional oscillator.

D. Squeezing in output wave

It is also useful to find how optical losses affect output wave squeezing. Using Eq.(A43) one can calculate the squeezing factor \mathcal{X} (for the coherent quantum state, $\mathcal{X} = 1$):

$$\mathcal{X}(\Omega) \equiv \sqrt{\frac{\langle b_\zeta b_\zeta^+ + b_\zeta^+ b_\zeta \rangle}{\langle a_{\text{vac}} a_{\text{vac}}^+ + a_{\text{vac}}^+ a_{\text{vac}} \rangle}} \quad (71)$$

The result of this calculation yields squeezing factor \mathcal{X} as a function of Ω . For particular case $\eta = 0$ the profile is given in Fig. 6. The top plot correspond to the lossless case ($\mathcal{A}_0 = 0$), the bottom one — to the case when $|\mathcal{A}_0| = 1$.

We see that in both cases the squeezing monotonously increases with increase in homodyne angle. More important is the fact that the values of squeezing factor are close to one. It confirms our assumption that it is the optical rigidity rather than pondermotive nonlinearity, *i.e.* the meter noises cross-correlation (as source of squeezing) that produces the major input into the sensitivity gain.

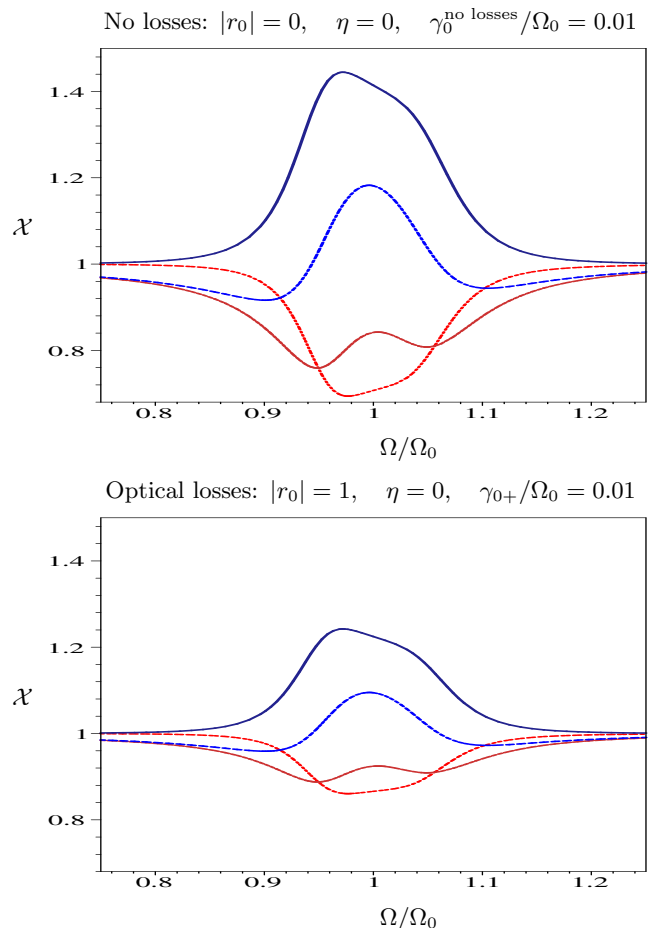

FIG. 6: The plots of squeezing factor \mathcal{X} as function on frequency Ω for zero losses, homodyne angle varies from $\alpha = 0$ (lower curve) through $\alpha = \pi/6, \pi/3$ to $\alpha = \pi/2$ (upper curve) and $\eta = 0$. Top: no loss case, $\gamma_0^{\text{no losses}}/\Omega_0 = 0.01$. Bottom: Non-zero losses case $|r_0| = 1, \gamma_{0+}/\Omega_0 = 0.01$.

V. CONCLUSION

The optical rigidity which can be created in the signal-recycled configuration of laser interferometric gravitational-wave detectors turns the detector test masses into oscillators and thus allows to obtain narrow-band sensitivity better than the Standard Quantum Limit for a free test mass. This method of overcoming the Standard Quantum Limit does not rely on squeezed quantum states of the optical field and thus it is much less vulnerable to optical losses.

Moreover, sophisticated frequency dependence of this rigidity makes it possible to implement the “double resonance” regime which provides narrow-band sensitivity better than the Standard Quantum Limits for both a free test mass and an ordinary harmonic oscillator.

The “double resonance” regime may be useful to detect gravitational waves, e.g. from pulsars. Knowing pulsar parameters one can tune the bandwidth and sensitivity in the optimal way. It is important that this tuning may be produced “on line” by varying signal recycling mirror position and adjusting circulating power.

Another advantage of the “double resonance” regime is its better sensitivity to wide-band signals. While an

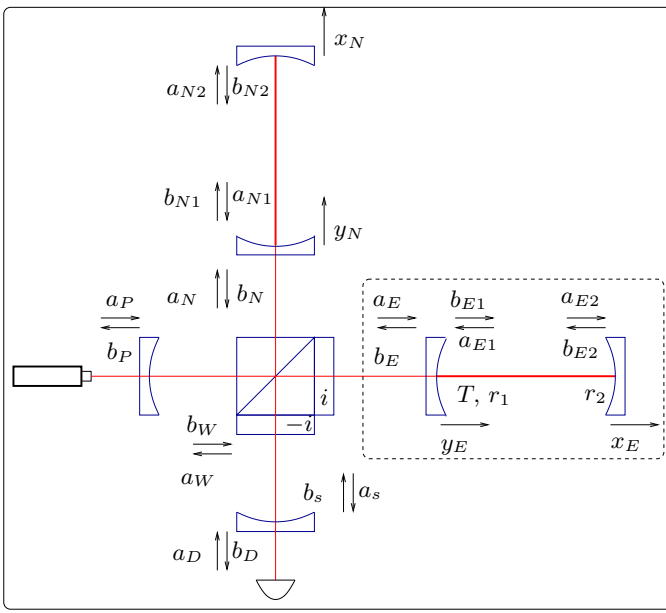

FIG. 7: Scheme of Advanced LIGO

ordinary harmonic oscillator provide approximately the same value of the the signal-to-noise ratio as a free test mass, in the case of a “double resonance” oscillator this parameter is limited only by the optical and mechanical losses and other noise sources of non-quantum origin. Estimates based on the Advanced LIGO parameters values shown that the “double resonance” regime can provide more than tenfold increase of the wide-band signal-to-noise ratio.

Acknowledgments

We would like to extend our gratitude to V.B. Braginsky and Y. Chen for stimulating discussions. This work was supported by LIGO team from Caltech and in part by NSF and Caltech grant PHY-0353775, as well as by the Russian Foundation of Fundamental Research, grant No. 03-02-16975-a.

Appendix A: Analysis of Advanced LIGO interferometer.

1. Notations and approximation

We consider Advanced LIGO interferometer with signal recycling (SR) mirror and power recycling (PR) mirror as shown in Fig.7. SR, PR mirrors and beam splitter are immobile and have no optical losses. We assume that both Fabry-Perot (FP) cavities in the east and north arms are identical: each input mirror has transmittance $T \ll 1$ and reflectivity $R_1 = \sqrt{1 - T^2 - \mathcal{A}_1^2}$, each end mirror has reflectivity $R_2 = \sqrt{1 - \mathcal{A}_2^2}$, where $\mathcal{A}_1, \mathcal{A}_2$ are optical loss coefficients for input and end mirrors correspondingly. The end mirrors and input mirrors have equal masses m and they can move as free masses.

The contribution of losses in SR mirror and in beam splitter is small as compared with contribution of losses

in mirrors in arms which is larger by factor $\sim 1/T^2$ — consequently we assume in our analysis that SR mirror and beam splitter have no optical losses.

We consider “dark port” regime when no regular optical power comes to detector in the signal port. In this case the power recycling mirror is used only to increase the mean power delivered to the beam splitter and no fluctuational fields from the laser (west arm) access detector in the south arm.

Upper letters denote the mean complex amplitudes, lower case letters denote operator describing fluctuations and signal. south arm, b_D is the operator of Fig.7). The electric field E in propagating wave can be written as sum of large mean field and small component (see details in [23]):

$$E \simeq \sqrt{\frac{2\pi \hbar \omega_o}{S c}} e^{-i\omega_o t} \left(A + \int_{-\infty}^{\infty} a e^{-i\Omega t} \frac{d\Omega}{2\pi} \right) + \{\text{h.c.}\},$$

$$I = \hbar \omega_p |A|^2, \quad a \equiv a(\omega_o + \Omega), \quad a_- \equiv a(\omega_o - \Omega)$$

$$[a(\omega_o \pm \Omega), a^+(\omega_o \pm \Omega')] = 2\pi \delta_0(\Omega - \Omega'),$$

where A is the complex amplitude, S is the cross section of the light beam, c is the velocity of light, I is the mean power of the light beam, a and a^+ are the annihilation and creation operators. We consider sidebands $\omega_o \pm \Omega$ about carrier ω_o with side band frequencies Ω in gravitational wave range ($\Omega/2\pi \in 10 \dots 1000$ Hz). Detailed notations of wave amplitudes and mirror displacements are given on Fig.7.

2. Arm cavities

First we consider the fields propagating in FP cavity in the east arm shown in dashed box on Fig.7 (formulas for FP cavity in the north arm are the same with obvious substitutions in subscripts $E \rightarrow N$). Below we assume that the following conditions are fulfilled:

$$\frac{L\Omega}{c} \ll 1, \quad T, \mathcal{A}_1, \mathcal{A}_2 \ll 1, \quad (\text{A1})$$

where L is the distance between the mirrors in arms (4 km for LIGO).

We start with a set of equations for mean amplitudes

$$B_{E1} = iTA - R_1 A_{E1}, \quad B = iTA_{E1} - R_1 A_E, \quad (\text{A2})$$

$$A_{E1} = B_{E2} e^{i\omega_o L/c} = -R_2 B_{E1} e^{2i\omega_o L/c}.$$

Below we assume that the carrier frequency of the incident wave ω_o is equal to the eigenfrequency of each FP cavity, i.e. $e^{i\omega_o L/c} = 1$. So we obtain

$$B_{E1} = TA_E, \quad B_{E2} \simeq -B_{E1}, \quad B_E = \mathcal{R}A_E, \quad (\text{A3})$$

$$\mathcal{T} \equiv \frac{iT}{1 - R_1 R_2} \simeq \frac{2i\gamma_{\text{load}}}{T\gamma}, \quad (\text{A4})$$

$$\mathcal{R} \equiv \frac{-R_1 + R_2(1 - r_1^2)}{1 - R_1 R_2} \simeq \frac{\gamma_-}{\gamma}, \quad (\text{A5})$$

$$\gamma = \gamma_{\text{load}} + \gamma_{\text{loss}}, \quad \gamma_- = \gamma_{\text{load}} - \gamma_{\text{loss}},$$

$$\gamma_{\text{load}} = \frac{cT^2}{4L}, \quad \gamma_{\text{loss}} = \frac{c\mathcal{A}^2}{4L},$$

$$\mathcal{A} = \sqrt{\mathcal{A}_1^2 + \mathcal{A}_2^2}.$$

To calculate fluctuational components of field we start from the set of equations:

$$b_{E1} = iTa_E - R_1 a_{E1} + i\mathcal{A}_1 e_{E1} + R_1 A_{E1} 2iky_E, \quad (\text{A6})$$

$$b_E = iTa_{E1} - R_1 a_E - R_1 A_E 2iky_E + i\mathcal{A}_1 e_{E1}, \quad (\text{A7})$$

$$a_{E1} = \theta R_2 (-a_{2E} - A_{2E} 2ikx_E) + i\mathcal{A}_2 e_{2E}. \quad (\text{A8})$$

Here e_{1E} , e_{2E} is vacuum fields appearing due to losses. We denote $\theta = e^{i(\omega_o + \Omega)L/c}$ using obvious approximation $\theta \simeq 1 + i\Omega L/c$,

Substituting (A8) into (A6) and using conditions (A1) we obtain:

$$b_{E1} \simeq \mathcal{T}_\Omega a_E + e_{E1} \mathcal{T}_\Omega + \frac{\mathcal{T}_\Omega B_{E1} 2ik(x_E - y_E)}{iT}, \quad (\text{A9})$$

$$b_{2E} \simeq -b_{E1}, \quad a_{2E} \simeq b_{E1}, \quad a_{E1} \simeq -b_{E1}, \quad (\text{A10})$$

$$\mathcal{T}_\Omega \equiv \frac{iT}{1 - R_1 R_2 \theta^2} \simeq \frac{2i\gamma_{\text{load}}}{T(\gamma - i\Omega)}, \quad (\text{A11})$$

$$e_E = \frac{e_{E1} \mathcal{A}_1 - e_{2E} \mathcal{A}_2}{\mathcal{A}},$$

Here we introduced operator e_E of vacuum fluctuations, which fulfill usual commutator relation $[e_E(\omega_o + \Omega), e_E^+(\omega_o + \Omega')] = 2\pi \delta_0(\Omega - \Omega')$.

Substitution of (A9) into (A7) under conditions (A1) allows us to get the formula for reflected field:

$$b_E = a_E \mathcal{R}_\Omega - ierT \mathcal{T}_\Omega - AT \mathcal{T}_\Omega 2ik(x_e - y_E), \quad (\text{A12})$$

$$\mathcal{R}_\Omega = \frac{-R_1 + R_2(1 - \mathcal{A}_1^2)\theta^2}{1 - R_1 R_2 \theta^2} \simeq \frac{\gamma_- + i\Omega}{\gamma - i\Omega} \quad (\text{A13})$$

3. Beam splitter

We assume that lossless beam splitter has transmittance and reflection factors equal to $i/\sqrt{2}$ and $-1/\sqrt{2}$, correspondingly. The additional phase shift $\pi/2$ is added to the west arm and $-\pi/2$ to the south one. It is convenient to introduce new variables

$$a_{(\pm)} = \frac{a_E \pm a_N}{\sqrt{2}}, \quad b_{(\pm)} = \frac{b_E \pm b_N}{\sqrt{2}}. \quad (\text{A14})$$

For these variables beam splitter equations read:

$$a_W = -b_{(+)}, \quad a_s = -b_{(-)}, \quad (\text{A15a})$$

$$a_{(+)} = -b_W, \quad a_{(-)} = -b_s. \quad (\text{A15b})$$

These equations are valid both for the zero and the first approximations as the beam splitter is a linear system.

Now we can consider the fields in entire interferometer. For our mean amplitudes of (\pm) variables we have

$$B_{(\pm)} = \mathcal{R}A_{(\pm)} \quad (\text{A16})$$

It is easy to note that the set of equations splits into two independent sets: one for W and $(+)$ and second for S and $(-)$. The “ $S, (-)$ ” set has only trivial zero solution since $A_D = 0$. Therefore,

$$A_E = A_N = \frac{A}{\sqrt{2}}, \quad B_E = B_N = \frac{\mathcal{R}A}{\sqrt{2}}, \quad (\text{A17a})$$

$$A_{E1} = A_{N1} = \frac{-\Theta^2 B_1}{\sqrt{2}}, \quad B_{E1} = B_{N1} = \frac{B_1}{\sqrt{2}}, \quad (\text{A17b})$$

From this point on we omit indices $+$ for the sake of simplicity, A is the complex mean amplitude left in the beam splitter.

4. Output field

The signal wave, registered by detector in the south arm (“ $S, (-)$ ” mode) is coupled with the differential motion of the mirrors, i.e. it has a part proportional to differential coordinate

$$x = \frac{(x_E - y_N) - (x_N - y_N)}{2} \quad (\text{A18})$$

coupled with the gravitation-wave signal. We are interested in “ $S, (-)$ ” mode and below we omit subscripts $(-)$ for $a_{(-)}$, $b_{(-)}$.

From equations for the south arm

$$b_D = -R_s a_D + iT_s \theta_s a_s, \quad (\text{A19a})$$

$$b_s = -R_s \theta_s^2 a_s + iT_s \theta_s a_D. \quad (\text{A19b})$$

(here $\theta_s = e^{i(\omega_o + \Omega)l/c}$, l is the optical length between SR mirror and input mirror in the arm) one can obtain the following formulas for fluctuational component of the output field:

$$b_D \simeq \mathcal{R}_s a_D - \mathcal{T}_s \mathcal{T}_\Omega (2ikB_1 x + iAe), \quad (\text{A20})$$

$$e = \frac{e_E - e_N}{\sqrt{2}} \quad (\text{A21})$$

Here we introduced the “generalized” transparency \mathcal{T}_s and reflectivity \mathcal{R}_s of “ $S, (-)$ ” mode of interferometer:

$$\mathcal{T}_s = \frac{-iT_s \theta_s}{1 + \mathcal{R}_\Omega R_s \theta_s^2}, \quad \mathcal{R}_s = \frac{-(R_s + \mathcal{R}_\Omega \theta_s^2)}{1 + \mathcal{R}_\Omega R_s \theta_s^2}, \quad (\text{A22})$$

Due to small value of $l \ll L$ we consider below θ_s a constant not depending on Ω .

It is useful to rewrite formulas (A22) in approximation (A1) denoting $\theta_s = i e^{i\phi}$:

$$\mathcal{R}_s \simeq G \times \frac{\Gamma_-^* + i\Omega}{\Gamma_- - i\Omega}, \quad G = \frac{R_s + e^{2i\phi}}{1 + R_s e^{2i\phi}} \quad (\text{A23})$$

$$\Gamma = \gamma_0 - i\delta_0, \quad \Gamma_- = \gamma_{0-} - i\delta_0, \quad (\text{A24})$$

$$\gamma_0 = \gamma_0^{\text{load}} + \gamma_0^{\text{loss}}, \quad \gamma_{0-} = \gamma_0^{\text{load}} - \gamma_0^{\text{loss}}, \quad (\text{A25})$$

$$\gamma_0^{\text{load}} = \frac{\gamma_{\text{load}} T_s^2}{|1 + R_s e^{2i\phi}|^2} = \frac{c T^2 T_s^2}{4L |1 + R_s e^{2i\phi}|^2}, \quad (\text{A26})$$

$$\gamma_0^{\text{loss}} = \gamma_{\text{loss}} = \frac{cA^2}{4L}, \quad (\text{A27})$$

$$\delta_0 = \frac{2R_s \gamma_{\text{load}} \sin 2\phi}{|1 + R_s e^{2i\phi}|^2} = \frac{2R_s \gamma_0^{\text{load}} \sin 2\phi}{T_s^2} \quad (\text{A28})$$

$$\mathcal{T}_s = \frac{-iT_s \theta_s}{1 + \mathcal{R}_\Omega R_s \theta_s^2} = \frac{T_s e^{i\phi} [\gamma - i\Omega]}{[1 + R_s e^{2i\phi}] [\Gamma - i\delta_0]}.$$

Here δ_0 is the detuning, γ_0 is the relaxation rate of our difference mode (“ $S, (-)$ ” mode) which can be presented

as a sum of “loaded” and “intrinsic” rates. “Intrinsic” relaxation rate γ_0^{loss} is exclusively provided by intrinsic losses in mirrors in arms while “loaded” relaxation rate γ_0^{load} is provided only by transparencies of SR and input mirrors. Note that for Advanced LIGO relaxation rate $\gamma_0 \simeq 2 \text{ s}^{-1}$ — it is much less than the mean frequency of gravitational wave range $\Omega \sim 2\pi \times 100 \text{ s}^{-1}$.

5. Pondermotive forces

To calculate pondermotive force acting on movable mirrors in interferometer arms we should write down the equation for differential field $b_1 = (b_{E1} - b_{N1})/\sqrt{2}$ in approximation (A1):

$$b_1 \simeq \mathcal{T}_s \mathcal{T}_\Omega \left(a_D + \frac{(1 + R_s e^{2i\phi})}{T_s e^{i\phi}} \left[r e + \frac{2B_1 k z}{T} \right] \right) \quad (\text{A29})$$

The incident wave acts on the mirror with force proportional to square of amplitude module; and we keep only the cross term of this square.

$$\mathcal{F} \simeq \int_{-\infty}^{\infty} F(\Omega) e^{-i\Omega t} \frac{d\Omega}{2\pi}, \quad F(\Omega) = \hbar k (A^* a + A a_-^+)$$

First we write down the formulas for forces acting on the back mirrors. The difference between the forces acting on the east and north back mirrors is equal to:

$$F_2 \simeq 2\hbar k (A_2^* a_2 + A_2 a_{2-}^+ + B_2^* b_2 + B_2 b_{2-}^+), \quad (\text{A30})$$

where $A_2 = (A_{E2} - A_{N2})/\sqrt{2}$, $a_2 = (a_{E2} - a_{N2})/\sqrt{2}$ and so on (recall that we continue considering “S(−)” mode). One can extract two terms in formula for F_2 :

$$F_2 = F_{\text{meter}} + F_{\text{rigid}}, \quad (\text{A31})$$

where the first term corresponds to fluctuational component (back action) and the second one — to the regular force depending on mirrors positions (optical rigidity). The formula for F_{meter} is the following

$$F_{\text{meter}} \simeq \frac{2i\hbar\omega_o T_s T B_1^* e^{i\phi} (a_D + \mathcal{A}_0 e)}{(1 + R_s e^{2i\phi})(\Gamma - i\Omega)} - \frac{2i\hbar\omega_o T_s T B_1 e^{-i\phi} (a_{D-}^+ + \mathcal{A}_0^* e_-^+)}{(1 + R_s e^{-2i\phi})(\Gamma^* - i\Omega)}, \quad (\text{A32})$$

where

$$\mathcal{A}_0 = \frac{\mathcal{A}(1 + R_s e^{2i\phi})}{T T_s e^{i\phi}} \quad (\text{A33})$$

is the effective loss factor.

The equation for optical rigidity K has the following shape

$$K \equiv \frac{-F_{\text{rigid}}}{x} = \frac{16\hbar k^2 \gamma_{\text{load}} \delta_0 |B_1|^2}{T^2 \mathcal{D}} = \frac{8k I_c \delta_0}{LD}, \quad (\text{A34})$$

$$\mathcal{D} = (\Gamma - i\Omega)(\Gamma^* - i\Omega), \quad I_c = \frac{\hbar\omega_o}{2} |B_1|^2, \quad (\text{A35})$$

We see that optical rigidity K is proportional to detuning δ_0 of the difference mode of the interferometer. This

detuning can be only introduced by displacement of SR mirror (while Fabry-Perot cavities in arms remain in optical resonance).

In approximation (A1) the forces acting on the back mirrors are approximately equal (with negative sign) to the forces acting on input mirrors — the difference is negligible. So for the difference coordinate x we have the following equation:

$$Z(\Omega)x = F_{\text{meter}} + F_{\text{signal}}, \quad (\text{A36})$$

where

$$Z(\Omega) = -m\Omega^2 + K \quad (\text{A37})$$

and

$$F_{\text{signal}} = \frac{m\Omega^2 L h}{2} \quad (\text{A38})$$

is the signal force due to action of gravitational wave, h — is the dimensionless gravitational-wave signal.

6. Output signal

We see from formula (A32) that the back action force is produced by sum of fluctuational fields: a_D from signal port and e due to losses in mirrors. It is useful to introduce a new pair of independent fluctuational fields p and q (the new basis) as following:

$$p = G \frac{\Gamma^* + i\Omega}{\Gamma - i\Omega} \frac{a_D + \mathcal{A}_0 e}{\sqrt{1 + |\mathcal{A}_0|^2}}, \quad (\text{A39a})$$

$$q = \frac{-\mathcal{A}_0^* a_D + e}{\sqrt{1 + |\mathcal{A}_0|^2}}. \quad (\text{A39b})$$

These two bases are equivalent — both pairs a_D , e and p , q describe vacuum fluctuations (we do not consider possible squeezing of field a_D).

Then we can rewrite formulas for the fluctuational force F_{fl} and output field b_D in a more compact form:

$$F_{fl} \simeq \frac{8i\hbar k B_1^* \gamma_0 (1 + R_s e^{2i\phi})}{T T_s e^{i\phi} (\Gamma^* + i\Omega)} \times \frac{p}{\sqrt{1 + |\mathcal{A}_0|^2}} + \{\text{h.c.}\}_{-\Omega}, \quad (\text{A40a})$$

$$b_D = \frac{p}{\sqrt{1 + |\mathcal{A}_0|^2}} + \frac{q \mathcal{A}_0^*}{\sqrt{1 + |\mathcal{A}_0|^2}} - \mathcal{T}_s \mathcal{T}_\Omega B_1 i k z. \quad (\text{A40b})$$

Calculating the difference position x from (A36) and substituting it into (A40b) one can obtain the final formula for the output field b_D :

$$b_D = \frac{q \mathcal{A}_0^*}{\sqrt{1 + |\mathcal{A}_0|^2}} + \frac{-m\Omega^2}{Z(\Omega) \sqrt{1 + |\mathcal{A}_0|^2}} \times \left\{ p \left(1 - \frac{iJ\Gamma^*}{\Omega^2((\Gamma^*)^2 + \Omega^2)} \right) + p_-^+ \left(\frac{-iJ\gamma_0 G}{\Omega^2(\Gamma^2 + \Omega^2)} + \frac{i\hbar\sqrt{2J\gamma_0 G}}{\Omega h_{SQL}(\Gamma - i\Omega)} \right) \right\}, \quad (\text{A41})$$

where

$$J = \frac{8kI_c}{mL}. \quad (\text{A42})$$

This formula has two terms. The first one ($\sim q$) is proportional to the effective loss factor \mathcal{A}_0 and appears due to the optical losses. The second term has the same form as for no losses case — compare with Eq.(16) in [14] — with weighted multiplier $1/\sqrt{1+|\mathcal{A}_0|^2}$ and substituted damping rate γ_0 accounting for losses in [14]. It is the background to interpret formula (A41) as field reflected from lossless interferometer (with damping rate γ_0) and then passed through grey filter with total loss factor $|\mathcal{A}_0|$ which decreases our field and adds fluctuations (the first term).

It is important that the second term has multiplier $m\Omega^2/Z(\Omega)$ which increases the relative contribution of the second term at frequencies close to mechanical resonance (when $|Z(\Omega)| \ll m\Omega^2$) while the first term does not depend on frequency — it demonstrates the advantage of “real” rigidity and may explain the relatively weak degradation of sensitivity due to optical losses.

7. Sensitivity

In gravitational wave antenna one registers the quadrature component b_ζ of output fields using the balanced homodyne scheme (not shown in Fig.7):

$$\begin{aligned} b_\zeta &= \frac{b_D e^{-i\zeta} + b_{D-}^+ e^{i\zeta}}{\sqrt{2}} \\ &= \frac{-m\Omega^2}{(Z(\Omega)\sqrt{2(1+|\mathcal{A}_0|^2)}} \left\{ A_q (q\mathcal{A}_0^* e^{-i\zeta} + q_-^+ \mathcal{A}_0 e^{i\zeta}) \right. \\ &\quad \left. + A_p p + A_p^* p_-^+ + A_s \frac{h_s}{h_{SQL}(\Omega_0)} \right\}, \end{aligned} \quad (\text{A43a})$$

$$A_q = \frac{-m\Omega^2 + K}{-m\Omega^2} = 1 - \frac{J\delta_0}{\Omega^2 \mathcal{D}}, \quad (\text{A43b})$$

$$A_p = \frac{e^{-i\zeta}[(\Gamma_+^*)^2 + \Omega^2 - iY\Gamma_+^* + iY\gamma_0 + e^{2i\alpha}]}{(\Gamma_+^*)^2 + \Omega^2}, \quad (\text{A43c})$$

$$\begin{aligned} A_s &= \frac{\sqrt{J\gamma_0 G}}{\Omega_0} \left(\frac{ie^{-i\alpha}}{\Gamma_+ - i\Omega} - \frac{ie^{i\alpha}}{\Gamma_+^* - i\Omega} \right) = \\ &= \frac{\sqrt{8J\gamma_0}}{\Omega_0} \frac{(\gamma_0 - i\Omega) \sin \alpha - \delta_0 \cos \alpha}{\mathcal{D}}, \end{aligned} \quad (\text{A43d})$$

$$\alpha = \zeta - \phi. \quad (\text{A43e})$$

Here and below we normalize dimensionless metric h_s by SQL sensitivity $h_{SQL}(\Omega_0)$ at some frequency Ω_0 .

Now we can write down one-sided spectral noise density S_h recalculated to variation of dimensionless metric h_s and normalize it to SQL sensitivity $h_{SQL}(\Omega_0)$:

$$\xi^2(\Omega) = \frac{S_h(\Omega)}{h_{SQL}(\Omega_0)^2} = \frac{2|A_q|^2 + 2|A_p|^2}{|A_s|^2} = \frac{P_1 + P_2 + P_3}{Q}, \quad (\text{A44a})$$

$$P_1 = \left[\Omega^4 - \Omega^2(\delta_0^2 - \gamma_0^2) + J(\delta_0 - \gamma_0 \sin 2\alpha) \right]^2, \quad (\text{A44b})$$

$$P_2 = \gamma_0^2 (2\delta_0 \Omega^2 - J(1 - \cos 2\alpha))^2, \quad (\text{A44c})$$

$$P_3 = |\mathcal{A}_0|^2 \left\{ [\Omega^4 - (\delta_0^2 + \gamma_0^2)\Omega^2 + J\delta_0]^2 + 4\gamma_0^2 \Omega^6 \right\}, \quad (\text{A44d})$$

$$Q = \frac{4J\gamma_0\Omega^4}{\Omega_0^2} |(\gamma_0 - i\Omega) \sin \alpha - \delta_0 \cos \alpha|^2, \quad (\text{A44e})$$

Note that without signal recycling mirror SQL sensitivity in LIGO lossless interferometer can be achieved at working frequency $\Omega_0 = \gamma$ if the optical power I_c is equal to the optimal one $I_{SQL}(\Omega_0)$ [1, 23]:

$$I_{SQL}(\Omega_0) = \frac{m\Omega_0^3 Lc}{8\omega_o}, \quad \text{or} \quad \frac{J}{\Omega_0^3} = 1. \quad (\text{A45})$$

Although presentation (A44) is compact and convenient for numeric estimates, it can mask the physical structure of the noise. Due to this reason, we provide a more transparent form of this equation:

$$S_h(\Omega) = \frac{4}{m^2 L^2 \Omega^4} \left[\frac{\hbar^2}{S_x} + |Z_{\text{eff}}|^2 S_x + |Z|^2 S_{\text{loss}} \right], \quad (\text{A46})$$

where

$$S_x = \frac{\hbar}{2mJ\gamma_0} \frac{|\mathcal{D}|^2}{|(\gamma_0 - i\Omega) \sin \alpha - \delta_0 \cos \alpha|^2} \quad (\text{A47})$$

is the measurement noise,

$$S_{\text{loss}} = |\mathcal{A}_0|^2 S_x \quad (\text{A48})$$

is the noise created by the optical losses,

$$Z_{\text{eff}} = K_{\text{eff}} - m\Omega^2, \quad (\text{A49})$$

and

$$\begin{aligned} K_{\text{eff}} &= \frac{mJ}{|\mathcal{D}|^2} \left[\delta_0(\gamma_0^2 + \delta_0^2 - \Omega^2) \right. \\ &\quad \left. + \gamma_0(\gamma_0^2 - \delta_0^2 + \Omega^2) \sin 2\alpha - 2\delta_0\gamma_0^2 \cos 2\alpha \right]. \end{aligned} \quad (\text{A50})$$

is the effective rigidity.

8. Narrow-band case

Suppose that the observation frequency is close to the double resonance frequency $\Omega_0 = \delta_0/\sqrt{2}$ and the pumping power is close to the critical value:

$$\Omega = \Omega_0 + \nu, \quad (\text{A51a})$$

$$J = \frac{\Omega_0^3(1 - \eta^2)}{\sqrt{2}} \quad (\text{A51b})$$

where $|\nu| \ll 1$, $\eta^2 \ll 1$.

In this approximation,

$$P_1 \approx \Omega_0^4 \left(4\nu^2 - \eta^2 \Omega_0^2 - \frac{\gamma_0 \Omega_0}{\sqrt{2}} \sin 2\alpha \right)^2, \quad (\text{A52a})$$

$$P_2 \approx 2\gamma_0^2 \Omega_0^6 (1 + \cos^2 \alpha)^2, \quad (\text{A52b})$$

$$P_3 \approx |\mathcal{A}_0|^2 \Omega_0^4 [(4\nu^2 - \nu^2 \Omega_0^2)^2 + 4\gamma_0^2 \Omega_0^2], \quad (\text{A52c})$$

$$Q \approx 2\sqrt{2}\gamma_0 \Omega_0^7 (1 + \cos^2 \alpha), \quad (\text{A52d})$$

and

$$Z \approx m(4\nu^2 - \eta^2\Omega_0^2 - 2i\Omega_0\gamma_0), \quad (\text{A53a})$$

$$Z_{\text{eff}} \approx m \left(4\nu^2 - \eta^2\Omega_0^2 - \frac{\Omega_0\gamma_0}{\sqrt{2}} \sin 2\alpha \right), \quad (\text{A53b})$$

$$S_x \approx \frac{\hbar}{\sqrt{2}m\gamma_0\Omega_0(1 + \cos^2\alpha)}. \quad (\text{A53c})$$

In this approximation we have the following formula for the sensitivity ξ :

$$\begin{aligned} \xi^2(\nu) &\approx \frac{\gamma_0}{\Omega_0} \frac{(1 + \cos^2\alpha)}{\sqrt{2}} + \frac{1}{2\sqrt{2}\gamma_0\Omega_0^3(1 + \cos^2\alpha)} \\ &\times \left\{ \left(4\nu^2 - \eta^2\Omega_0^2 - \frac{\gamma_0\Omega_0}{\sqrt{2}} \sin 2\alpha \right)^2 \right. \\ &\left. + |\mathcal{A}_0|^2 \left[(4\nu^2 - \eta^2\Omega_0^2)^2 + 4\Omega_0^2\gamma_0^2 \right] \right\}. \quad (\text{A54}) \end{aligned}$$

Using the following notations:

$$\eta_\alpha^2 = \eta^2 + \frac{\gamma_0 \sin 2\alpha}{\sqrt{2}\Omega_0(1 + |\mathcal{A}_0|^2)}, \quad (\text{A55a})$$

$$|\mathcal{A}_\alpha|^2 = \frac{\sqrt{2}|\mathcal{A}_0|^2}{1 + \cos^2\alpha}, \quad (\text{A55b})$$

and taking into account that

$$\gamma_0 = \gamma_0^{\text{loss}} \left(1 + \frac{1}{|\mathcal{A}_0|^2} \right), \quad (\text{A56})$$

Eq. (A54) can be rewritten in a more compact form:

$$\xi^2(\nu) \approx \frac{(4\nu^2 - \eta_\alpha^2\Omega_0^2)^2}{4g\Omega_0^4} + gC, \quad (\text{A57})$$

where

$$g = \frac{\gamma_0^{\text{loss}}}{\Omega_0|\mathcal{A}_\alpha|^2}, \quad (\text{A58})$$

$$C = 1 + \frac{3}{\sqrt{2}} |\mathcal{A}_\alpha|^2 + |\mathcal{A}_\alpha|^4. \quad (\text{A59})$$

9. Signal-to-noise ratio

In the narrow-band case, the main contribution into the integral of the signal-to-noise ratio is produced in vicinity of Ω_0 . In this case we can use approximation (A57) and expand the limits of integration over ν from $-\infty$ to ∞ and making substitution $x = \sqrt{2}\nu/\Omega_0\sqrt{g}C^{1/4}$ with notation $a = \eta_\alpha^2/2g\sqrt{C}$:

$$\begin{aligned} \text{SNR} &= \frac{2}{\pi} \int_0^\infty \frac{|h(\Omega)|^2 d\Omega}{S_h(\Omega)} \approx \frac{2}{\pi} \frac{|h(\Omega_0)|^2}{h_{\text{SQL}}^2(\Omega_0)} \int_{-\infty}^\infty \frac{d\nu}{\xi^2(\nu)} \\ &= \frac{2|h(\Omega)|^2\Omega_0}{\pi h_{\text{SQL}}^2(\Omega_0)} \times \frac{1}{\sqrt{2g}C^{3/4}} \int_{-\infty}^\infty \frac{dx}{1 + (x^2 + a^2)^2} \\ &= \frac{|h(\Omega)|^2\Omega_0}{h_{\text{SQL}}^2(\Omega_0)} \times \frac{1}{\sqrt{2g}C^{3/4}} \left(\frac{1}{\sqrt{a+i}} + \frac{1}{\sqrt{a-i}} \right) = \end{aligned}$$

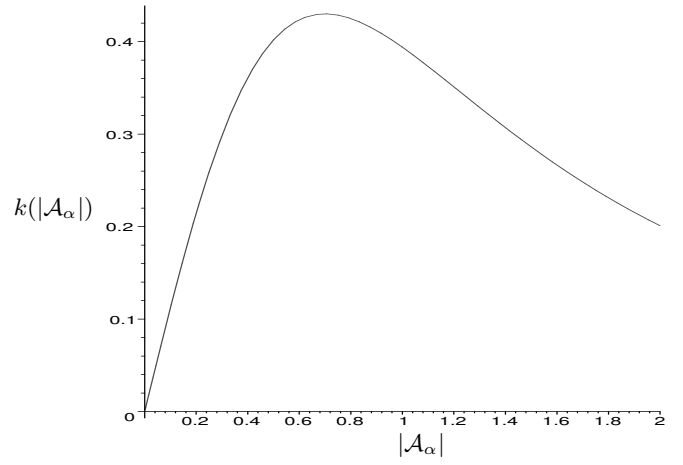

FIG. 8: Dependence of the signal-to-noise ratio on $|\mathcal{A}_\alpha|$ at optimal η_α^2 (A61).

$$= \frac{|h(\Omega)|^2\Omega_0}{h_{\text{SQL}}^2(\Omega_0)} \times \frac{1}{\sqrt{2g}C^{3/4}} \times \frac{\sqrt{a + \sqrt{a^2 + 1}}}{\sqrt{2}\sqrt{a^2 + 1}} \quad (\text{A60})$$

The maximum of this expression is achieved, if

$$a = \frac{1}{\sqrt{3}}, \quad \text{or} \quad \eta_\alpha^2 = \frac{2g\sqrt{C}}{\sqrt{3}}, \quad (\text{A61})$$

and it is equal to:

$$\text{SNR} = k(|\mathcal{A}_\alpha|) \times \frac{|h(\Omega)|^2\Omega_0}{h_{\text{SQL}}^2(\Omega_0)} \sqrt{\frac{\Omega_0}{\gamma_0^{\text{loss}}}}, \quad (\text{A62})$$

where

$$k(|\mathcal{A}_\alpha|) = \frac{3^{3/4}|\mathcal{A}_\alpha|}{2C^{3/4}} \quad (\text{A63})$$

is dimensionless function plotted in Fig. 8. It attains the maximum at

$$|\mathcal{A}_\alpha| = \sqrt{\frac{\sqrt{73} - 3}{8\sqrt{2}}} \approx 0.61 \quad (\text{A64})$$

and it is equal to

$$\frac{2^{7/4}\sqrt{\sqrt{73} - 3}}{(23 + 3\sqrt{73})^{3/4}} \approx 0.43. \quad (\text{A65})$$

Appendix B: Gain in spectral density for simplified model without optical losses

Starting with this Appendix we simplify the model system. In particular, we assume here, that there is no optical losses in the system we examine. When considering the frequency-dependent rigidity based system, the approximate formula (4) is used.

1. Conventional harmonic oscillator

Spectral density of the total meter noise (37) is equal to:

$$S_{\text{sum}}(\Omega) = S_F(\Omega) + |Z(\Omega)|^2 S_x(\Omega), \quad (\text{B1})$$

where $Z(\Omega)$ is the spectral image of the differential operator \mathbf{Z} . In case of a conventional harmonic oscillator,

$$|Z(\Omega)|^2 = (-m\Omega^2 + K)^2, \quad (\text{B2})$$

and in close vicinity of the resonance frequency $\Omega_0 = \sqrt{K/m}$,

$$|Z(\Omega)|^2 \approx 4m^2\Omega_0^2\nu^2, \quad (\text{B3})$$

and

$$\xi^2(\Omega) \equiv \frac{S_{\text{sum}}(\Omega)}{2\hbar m\Omega^2} \approx \xi_{\text{min}}^2 + \frac{\nu^2}{\xi_{\text{min}}^2\Omega_0^2}, \quad (\text{B4})$$

where

$$\nu = \Omega - \Omega_0, \quad |\nu| \ll \Omega_0, \quad (\text{B5})$$

$$\xi_{\text{min}}^2 = \frac{S_F(\Omega_0)}{2\hbar m\Omega_0^2}, \quad (\text{B6})$$

see Eqs (38, 56).

Let us require that $\xi(\Omega)$ does not exceed a given value ξ_0 within as wide a frequency band $\Delta\Omega$ as possible. It is easy to show that this requirement is met if

$$\xi_{\text{min}} = \frac{\xi_0}{\sqrt{2}}, \quad (\text{B7})$$

and

$$\Delta\Omega = 2\xi_{\text{min}}^2\Omega_0. \quad (\text{B8})$$

Therefore,

$$\xi_0^2 = \frac{\Delta\Omega}{\Omega_0}. \quad (\text{B9})$$

2. Frequency-dependent rigidity

a. Double-resonance case

Consider now an oscillator with the frequency-dependent rigidity (4). In this case,

$$|Z(\Omega)|^2 = \frac{m^2(\Omega_+^2 - \Omega^2)^2(\Omega_-^2 - \Omega^2)^2}{(\Omega_+^2 + \Omega_-^2 - \Omega^2)^2} \quad (\text{B10})$$

[see Eq. (7)].

If the double-resonance condition (9) is fulfilled, then in close vicinity of the resonance frequency $\Omega_0 = \delta_0/\sqrt{2}$,

$$|Z(\Omega)|^2 \approx 16m^2\nu^4, \quad (\text{B11})$$

$$\xi^2(\Omega) \approx \xi_{\text{min}}^2 + \frac{4\nu^4}{\xi_{\text{min}}^2\Omega_0^4}. \quad (\text{B12})$$

Performing again the same optimization as in previous subsection, we can obtain that again $\xi_{\text{min}} = \xi_0/\sqrt{2}$, and

$$\xi_0 = \frac{\Delta\Omega}{\Omega_0}. \quad (\text{B13})$$

b. Two close resonances

In the sub critical pumping case (20),

$$|Z(\Omega)|^2 \approx m^2(4\nu^2 - \Omega_0^2\eta^2)^2, \quad (\text{B14})$$

$$\xi^2(\Omega) \approx \xi_{\text{min}}^2 + \frac{(4\nu^2 - \Omega_0^2\eta^2)^2}{4\xi_{\text{min}}^2\Omega_0^4}. \quad (\text{B15})$$

These functions has a local maximum at $\nu = 0$ and two minima at $\nu = \pm\Omega_0\eta/2$.

The same optimization as in two previous cases gives, that

$$\xi(\Omega_0) = \xi_0 = \sqrt{2}\xi_{\text{min}}, \quad (\text{B16})$$

$$\xi_0 = \frac{1}{\sqrt{2}} \frac{\Delta\Omega}{\Omega_0}, \quad (\text{B17})$$

and the optimal value of parameter η is equal to

$$\eta_c = \xi_0, \quad (\text{B18})$$

Appendix C: Gain in signal-to-noise ratio for simplified model without optical losses

1. Free test masses interferometer

Rewrite the signal-to-noise ratio (24) as follows:

$$\text{SNR} = \frac{2}{\pi} \int_0^\infty \frac{|F_{\text{signal}}(\Omega)|^2 d\Omega}{S_{\text{sum}}(\Omega)}. \quad (\text{C1})$$

For conventional interferometer (without optical springs), the total meter noise spectral density is equal to (see [23]):

$$S_{\text{sum}}(\Omega) = \frac{\hbar m}{2} \left[\frac{2\Omega_0^4}{\Omega_0^2 + \Omega^2} + \frac{\Omega^4(\Omega_0^2 + \Omega^2)}{2\Omega_0^4} \right]. \quad (\text{C2})$$

Therefore, in this case,

$$\begin{aligned} \text{SNR} &= \frac{8}{\pi\Omega_0^2 h_{\text{SQL}}^2(\Omega_0)} \int_0^\infty \frac{|h(\Omega)|^2 d\Omega}{\frac{2\Omega_0^4}{\Omega^4(\Omega_0^2 + \Omega^2)} + \frac{\Omega_0^2 + \Omega^2}{2\Omega_0^4}} \\ &= \mathcal{N} \times \frac{|h(\Omega_0)|^2 \Omega_0}{h_{\text{SQL}}^2(\Omega_0)}, \end{aligned} \quad (\text{C3})$$

where

$$\mathcal{N} = \frac{8}{\pi\Omega_0^3 |h(\Omega_0)|^2} \int_0^\infty \frac{|h(\Omega)|^2 d\Omega}{\frac{2\Omega_0^4}{\Omega^4(\Omega_0^2 + \Omega^2)} + \frac{\Omega_0^2 + \Omega^2}{2\Omega_0^4}}. \quad (\text{C4})$$

is the numeric factor depending on the gravitation-wave signal shape $h(\Omega)/|h(\Omega_0)|$.

2. Conventional harmonic oscillator

Substituting Eqs. (B1) and (B2) into Eq. (C1), we obtain, that for a conventional harmonic oscillator the signal-to-noise ratio is equal to:

$$\text{SNR} = \frac{2}{\pi} \int_0^\infty \frac{|F_{\text{signal}}(\Omega)|^2 d\Omega}{S_F(\Omega) + m^2 S_x(\Omega)(\Omega_0^2 - \Omega^2)^2}. \quad (\text{C5})$$

In the narrow-band case [see Eqs. (43, B5)], this equation can be presented as the following:

$$\begin{aligned} \text{SNR} &\approx \frac{2}{\pi} |F_{\text{signal}}(\Omega_0)|^2 \int_{-\infty}^{\infty} \frac{d\nu}{S_F(\Omega_0) + 4m^2\Omega_0^2 S_x(\Omega_0)\nu^2} \\ &= \frac{|F_{\text{signal}}(\Omega_0)|^2}{hm\Omega_0} = \frac{2|h(\Omega_0)|^2\Omega_0}{h_{\text{SQL}}^2(\Omega_0)}. \end{aligned} \quad (\text{C6})$$

3. Frequency-dependent rigidity

In similar way, using Eqs. (B1,B14) and (C1), we obtain, that for optical spring based oscillator,

$$\begin{aligned} \text{SNR} &\approx \frac{2}{\pi} |F_{\text{signal}}(\Omega_0)|^2 \\ &\quad \times \int_{-\infty}^{\infty} \frac{d\nu}{S_F(\Omega_0) + m^2 S_x(\Omega_0)(4\nu^2 - \Omega_0^2 \eta^2)} \\ &= \frac{\sqrt{2}|h(\Omega_0)|^2\Omega_0}{h_{\text{SQL}}^2(\Omega_0)} \frac{\xi_0^2}{\sqrt{(\xi_0^4 + \eta^4)(\sqrt{\xi_0^4 + \eta^4} - \eta^2)}}. \end{aligned} \quad (\text{C7})$$

In a pure double resonance case ($\eta = 0$),

$$\text{SNR} = \frac{\sqrt{2}}{\xi_0} \frac{|h(\Omega_0)|^2\Omega_0}{h_{\text{SQL}}^2(\Omega_0)}. \quad (\text{C8})$$

Slightly better result can be obtained for the case of two optimally placed resonances. If

$$\eta^2 = \frac{\eta_c^2}{\sqrt{3}} \equiv \frac{\xi_0^2}{\sqrt{3}}, \quad (\text{C9})$$

then

$$\text{SNR} = \frac{3^{3/4}}{\sqrt{2}\xi_0} \frac{|h(\Omega_0)|^2\Omega_0}{h_{\text{SQL}}^2(\Omega_0)}, \quad (\text{C10})$$

If the separation between the two resonance frequencies is too big, $\eta \gg \xi_0$ (but still $\eta \ll 1$), then

$$\text{SNR} = \frac{2}{\eta} \frac{|h(\Omega_0)|^2\Omega_0}{h_{\text{SQL}}^2(\Omega_0)}. \quad (\text{C11})$$

-
- [1] A.Buonanno, Y.Chen, Physical Review D **64**, 042006 (2001).
[2] A.Buonanno, Y.Chen, Physical Review D **65**, 042001 (2002).
[3] E.Gustafson, D.Shoemaker, K.A.Strain and R.Weiss, LSC White paper on detector research and development, 1999, LIGO Document T990080-00-D (www.ligo.caltech.edu/docs/T/T990080-00.pdf).
[4] P.Fritschel, Second generation instruments for the Laser Interferometer Gravitational-wave Observatory (LIGO), in *Gravitational Wave Detection, Proc. SPIE*, volume 4856-39, page 282, 2002.
[5] V.B.Braginsky, Sov. Phys. JETP **26**, 831 (1968).
[6] V.B.Braginsky, F.Ya.Khalili, *Quantum Measurement*, Cambridge University Press, 1992.
[7] V.B.Braginsky, M.L.Gorodetsky, F.Ya.Khalili, A.B.Matsko, K.S.Thorne and S.P.Vyatchanin, Physical Review D **67**, 082001 (2003).
[8] V.B.Braginsky, A.B.Manukin, ZhETF **52**, 986 (1967), *in Russian*.
[9] V.B.Braginsky, A.B.Manukin, ZhETF **58**, 1550 (1970), *in Russian*.
[10] V.B.Braginsky, F.Ya.Khalili, Physics Letters A **257**, 241 (1999).
[11] V.B.Braginsky, F.Ya.Khalili, S.P.Volikov, Physics Letters A **287**, 31 (2001).
[12] V.B.Braginsky, M.L.Gorodetsky, F.Ya.Khalili, Physics Letters A **232**, 340 (1997).
[13] F.Ya.Khalili, Physics Letters A **288**, 251 (2001).
[14] V.I.Lazebny, S.P.Vyatchanin, paper in preparation .
[15] A.Buonanno, Y.Chen, Physical Review D **67**, 062002 (2003).
[16] Jan Harms, Yanbei Chen, Simon Chelkovski, Alexander Franzen, Hennig Walbruch, Karsten Danzmann, and Roman Schnabel, Physical Review D **68**, 042001 (2003).
[17] A.Buonanno, Y.Chen, Physical Review D **69**, 102004 (2004).
[18] Yanbei Chen, private communication.
[19] S. P. Vyatchanin E. A. Zubova, Physics Letters A **201**, 269 (1995).
[20] S.P.Vyatchanin and A.B.Matsko, Sov. Phys. JETP **82**, 107 (1996).
[21] S.P.Vyatchanin and A.B.Matsko, Sov. Phys. JETP **83**, 690 (1996).
[22] S. P. Vyatchanin, Physics Letters A **239**, 201 (1998).
[23] H.J.Kimble, Yu.Levin, A.B.Matsko, K.S.Thorne and S.P.Vyatchanin, Physical Review D **65**, 022002 (2002).
[24] A.V.Syrtsev, F.Ya.Khalili, Sov. Phys. JETP **79**, 3 (1994).